



From: Planning Department

December 15, 2009

Subject: On Board Imager (OBI) Upgrade Memo

The following information should be reviewed with the Customer that is planning to upgrade their existing Clinac or Silhouette Edition Clinac with an On Board Imager (OBI).

Do not proceed to download an Installation Data Package until the serial number of the Varian Clinac, to be upgraded, has been confirmed with the Customer.

- ALL Clinac 2100, 21EX, 2300, and 23EX with the following serial numbers and **BELOW** will receive/use dedicated hardware only:

21XX - #2799 and below

23XX - # 499 and below

Download the “**Dedicated Hardware - Clinac On Board Imager (OBI) upgrade**” from this web page. (cut and paste this address)

http://www.varian.com/media/oncology/services_and_support/download/OBI-Clinac_dedicated_hardware.pdf

- ALL 2100, 21EX, 2300, 23EX and iX with the following serial numbers and **ABOVE** will receive/use integrated hardware only:

21XX - #2800 and above

23XX - # 500 and above

All Silhouette Edition Clinacs

All iX Models and Trilogy Clinacs

Download the “**Integrated Hardware – Clinac and Silhouette - On Board Imager (OBI) upgrade**” from this web page. (cut and paste this address)

http://www.varian.com/media/oncology/services_and_support/download/OBI-Clinac_integrated_hardware.pdf

For assistance or questions, contact your Varian Planning Representative from this web page-
http://www.varian.com/us/oncology/services_and_support/architectural_planning/contact.html

Varian Medical Systems
Planning Department
660 N. McCarthy Boulevard, MS-OS207
Milpitas, CA 95035
Direct - 408-232-4231
Fax - 408-232-4230
800-278-2747
Email: planning@varian.com

Varian Medical Systems • Planning Department
660 N. McCarthy Blvd., M/S – OS207 Milpitas, CA 95035
Phone (800) 278-2747 or (408) 232-4231 • Fax (408) 232-4230

VARIAN

medical systems

Installation Data Package



On-Board Imager (OBI) Upgrade for
Clinac 2100C/D, 21EX – Serial Number 2800 and above
Clinac 2300C/D, 23EX – Serial Number 500 and above
Silhouette Edition Clinac – All Serial Number
Equipment Information

English Version
October 2007

Printed or Digital (pdf) Installation Data Package

This is not the complete Installation Data Package (IDP). This section describes only information on specific equipment facility requirements for **On-Board Imager (OBI) Upgrade option**.

- Clinac 2100C/D, 21EX Serial Number 2800 and above
- Clinac 2300C/D, 23EX Serial Number 500 and above
- Silhouette Edition Clinac - All Serial Numbers

Refer to Section One Installation Data Package for complete system requirements
Section 1 Clinac 2100C/D, 2300C/D, 21EX, 23EX, Trilogy Equipment Information and General Information

Refer to Section Seven Installation Data Package for complete system requirements.
Section 7 Silhouette Edition Clinac Equipment Information and General Information

To obtain a printed copy of any of the Varian IDP's, contact the Varian Planning Department at the address below.

Planning Requirements for New Clinac Treatment Rooms

- All requirements for a standard Clinac 2100C/D, 2300C/D, 21EX, 23EX installation must be met to install the On-Board Imager (OBI) Upgrade option. Refer to Installation Data Package: Section One - Clinac 2100C/D, 2300C/D, 21EX, 23EX.
- All requirements for a standard Silhouette Edition Clinac installation must be met to install the On-Board Imager (OBI) Upgrade option. Refer to Installation Data Package: Section Seven - Silhouette Edition Clinac Equipment Information and General Information.
- All facility requirements for the installation of the On-Board Imager (OBI) Upgrade option will be in addition to the standard Clinac or Silhouette Edition Clinac installation requirements.

Planning Requirements for Upgrading Clinac Treatment Rooms

- Verification of existing facility requirements for a standard Clinac or Silhouette Edition Clinac medical linear accelerator to install the On- Board Imager (OBI) Upgrade option will be reviewed by Varian and the Customer.
- All facility requirements for the installation of the On-Board Imager (OBI) Upgrade option will be in addition to the standard Clinac or Silhouette Edition Clinac installation requirements.

Limitation of Liability

Every effort has been made to keep these files consistent with the documents in the IDP. These files are provided "as is" without warranty of any kind, either express or implied. The Architects and Engineers of Record to reflect any and all site-specific conditions and regional regulatory agency requirements shall modify these files. Varian shall not be liable for the accuracy or completeness of the files, any documents that include portions of them or any damages, direct, indirect, incidental or consequential, including damages for any lost profits or project delays that result from the use of the files included herein.

Contact the Varian Planning Department if you have questions.

Varian Medical Systems
Planning Department
911 Hansen Way, Bldg. 3 M/S C-165
Palo Alto, CA 94304-1028
(800) 278-2747
(650) 424-5945
(650) 424-6252 Fax

E-mail - planning@varian.com

Clinac / Silhouette On-Board Imager (OBI) Option Upgrade Notes

Information and Support

This is not the complete Installation Data Package (IDP). This section describes only information on specific equipment facility requirements for **On-Board Imager (OBI) Upgrade option** for Clinac 2100C/D, 2300C/D, 21EX, 23EX or Silhouette medical linear accelerators. Refer to Section One for the Clinac or Section Seven for the Silhouette Edition Clinac Installation Data Packages for complete system requirements. For more information, contact your nearest regional support office (<http://www.varian.com/support>) or Varian's main Planning Department at:

Varian Oncology Systems Marketing
Planning Department
911 Hansen Way, Bldg. 3 M/S C-165
Palo Alto, CA 94304-1028
(800) 278-2747
(650) 424-5945
(650) 424-6252 Fax
<http://www.varian.com/support>

Equipment Information

The **On-Board Imager (OBI)** x-ray system is an optional accessory to the Clinac high-energy accelerator used for patient positioning and provides high-resolution digital images for target localization. The x-ray system incorporates Varian's kV x-ray source and amorphous silicon flat-panel digital image detector, and is attached directly to the Clinac on a pair of robotic arms that move relative to each other. The On-Board Imager system includes hardware installed into the Silhouette cabinet. Additional Hardware at the Clinac console is the On-Board Imager workstation and the 4D Console workstation.

Equipment Options

To simplify the design process, we suggest that the Architect and Customer determine, as early as possible, all optional equipment configurations ordered or planned for the future.

Clinac 2100C/D, 21EX

Serial Number 2800 and above (yes/no)

Clinac 2300C/D, 23EX

Serial Number 500 and above (yes/no)

Silhouette edition Clinac

All Serial Number (yes/no)

New Construction

- All requirements for a standard Varian Clinac 2100C/D, 21EX, 2300C/D, 23EX or Silhouette Edition Clinac installation must be met to install the On-Board Imager (OBI) Upgrade option. Refer to Section One for the Clinac or Section Seven Installation Data Packages for complete system requirements and General information.

- All facility requirements for the installation of the On-Board Imager (OBI) Upgrade option will be in addition to the standard Varian Clinac or Silhouette installation requirements.

Upgrade of an existing Facility

- Verification of existing facility requirements for a standard Varian Clinac or Silhouette Edition Clinac medical linear accelerator to install the On-Board Imager (OBI) Upgrade option will be reviewed by Varian and the Customer.
- All facility requirements for the installation of the On-Board Imager (OBI) Upgrade option will be in addition to the standard Varian Clinac or Silhouette Edition Clinac installation requirements.

OBI Upgrade Requirements:

Architectural:

- Control console changes vary depending on the final Sales Order and existing configuration. If all the Varian options are purchased including a companion Varis Work Station there should be 6 quad outlets and 6 data drops. The control console should be a recommended minimum of 16'-0" linear ft. in length.

Structural:

- The existing base frame can be re-used for an OBI upgrade. However, Varian recommends the use of a 52" base frame. If, the existing frame is a 36" frame then, the Customer and the Varian Sales Mgr. should discuss the clinical implications of not replacing the frame.

Mechanical:

- The following heat loads are during Beam-On states. The OBI Option generates 4,265 btu/hr(1.24kW) additional heat load in the treatment room. (The existing "C" or "EX" series Clinac generates 17,060 btu/hr (5.0kW). The Modulator generates 10,237 btu/hr(3.0kW)) Consult a licensed Mechanical Engineer and review the capacity of the existing HVAC system.
- Control console workstations additional heat load 2,560 btu/hr(.75kW)

Electrical:

- The OBI is a KV imager and requires 480V, 60amp, 4 wire, 3-phase and ground and 60kva supply capacity.

- The Main Circuit Breaker (MCB) for the OBI can be located in the room adjacent to the Clinac / Silhouette Stand or adjacent to the 208V (MCB) at the Control Console area.

- Provide a 2" conduit / Cable tray from the new 480V OBI Main Circuit Breaker panel and terminate at the Clinac / Silhouette Stand.

- Providing an additional 4" conduit from the control console to the Clinac stand is recommended. Verify this requirement with Varian project management.

Clinac / Silhouette On-Board Imager (OBI) Option Upgrade Notes

OBI Upgrade Requirements: continued

Electrical: continued-

- Connections for two warning lights, usually red colored, incandescent (no fluorescent lighting) are provided. Locate over the door, on the outside of the treatment room. They may be required to blink when the x-ray is on. Verify local requirements with regional regulatory agencies.

"X-RAY ON" - warning light (maximum 24vdc @250ma)

"GENERATOR ON" - warning light (maximum 24vdc @250ma) The 24vdc @250ma signal can be used to control a Potter - Brumfield PRD11DG0-24, 24 Vdc (or equivalent) relay to switch higher voltage warning lights. The additional relay(s) can be installed into the existing relay junction box.

Shielding:

- Due to periodic changes in the shielding regulations and higher dose rates associated with this machine, all sites must have the shielding reviewed by the "Physicist of Record".

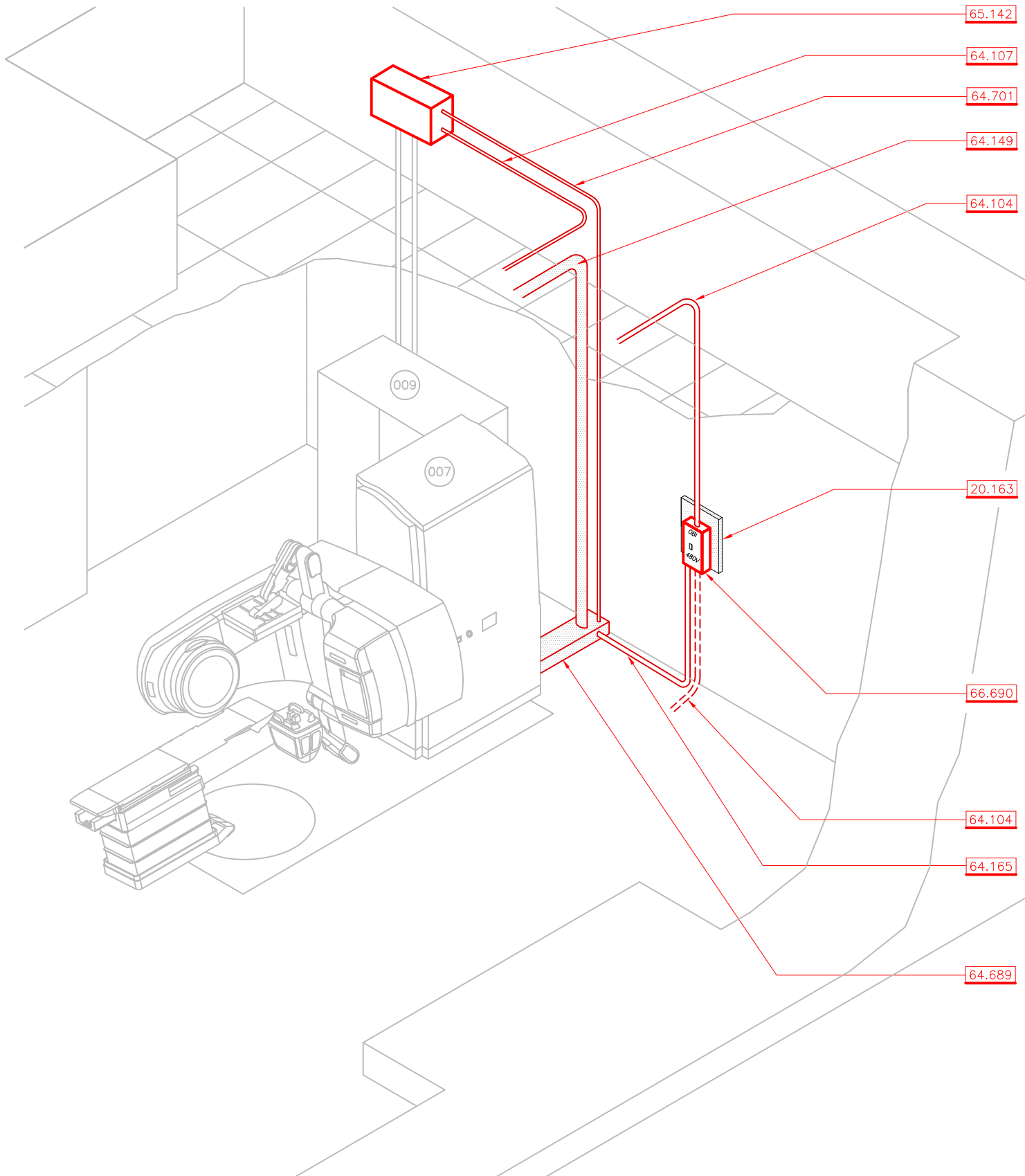

A Typical Room Isometric 10.124 10.691 53.092

		On-Board Imager Upgrade Option Room Configuration Clinac 2100C/D, 2300C/D, 21EX, 23EX				
	Not For Construction					
OCS.1.0 :page	planning dept.	© Varian Medical Systems 2004 All rights reserved.	230oct07	revision: 1	doc. #: 200047	page: OCS.1.0

10 - General Notes

10.124

The layouts shown on IDP drawings represent typical plans only. Clearances and wall thickness may vary.

10.691

All requirements for a standard Clinac 2100C(/D), 2300C/D, 21EX, 23EX, and Silhouette Edition Clinac installation must be met to install the On- Board Imager (OBI) Upgrade option.

Refer to the appropriate Installation Data Package:

- > Section One - Clinac 2100C(/D), 2300C/D, 21EX, 23EX
- > Section Seven - Silhouette Edition Clinac

20 - General Layout Notes

20.163

The OBI Circuit Breaker Panel may be recessed in the wall. If flush mounted, the Customer/Contractor will provide and install a mounting plate, 24" X 32" X 1" (61cm X 81cm X 2.5cm). Install on the wall and firmly attached to wall studs. The OBI circuit breaker mounting plate should be 48" A.F.F. to the bottom edge of the mounting plate.

53 - Ventilation

53.092

Provide ventilation sufficient for removal of OBI equipment air heat load as follows:

- > 1.25 kW (4265 Btu/hr) in the Clinac treatment room for OBI X-Ray on.
- > 0.6 kW (2050 Btu/hr) in the Clinac treatment room for OBI standby mode.
- > 0.75 kW (2560 Btu/hr) at the Clinac OBI Console

64 - Cable Access Runs

64.104

Provide one 2" (50) conduit between Main Power Feed Panel and OBI Circuit Breaker. This conduit may be installed under slab or run overhead into the treatment room.

64.107

Provide 1/2" (13) conduit between X-RAY warning light(s) and the Relay junction box.

64.149

Varian recommends installation of an additional 4" (100) conduit from the Control Console pull box and the stand. The length of this cable run shall not exceed 75 feet (22,900). Verify existing and additional conduit requirements with Varian Project Manager.

64.165

Provide one 2"(50) conduit between OBI Circuit Breaker and Clinac/Silhouette stand.

- > For new construction, this conduit may be installed under slab and terminated at the Base Frame pull box.
- > For renovations this conduit may be installed overhead and terminated at the Base Frame pull box.

64.689

Provide Conduit/Cable tray between rear wall and Clinac stand.

- > For new Treatment room construction, the Conduit/Cable tray may be installed in the floor slab.
- > For renovation of an existing Treatment room, the conduit /cable tray may be installed on top of the floor slab.

64.701

Provide 1/2" (13) conduit between Relay junction box and the cable tray.

65 - Pull / Junction Boxes

65.142

The Relay junction box shall be 12" x 12" x 6" deep (300 x 300 x 150). Locate box above finished ceiling (if accessible) near the Modulator Cabinet.

66 - Circuit Breakers / UVRs

66.690

The On- Board Imager main circuit breaker panel should be located in the control room or in the treatment room as desired. Verify location requirements with regulatory agencies or local code.

- > Main Circuit Breaker- recommended G.E. Catalog # OBI60A480V (includes 60Amp, three phase 400 - 480V circuit breaker, 60 amp., 480V contactor/120V coil installed in a Lockout/Tagout subpanel) or equivalent. The G.E. Catalog # OBI60A480V information is available from the Planning department web page: varian.com/support or contact your regional Planning Manager.

	[000] Refer to the Varian Components Chart at the end of this section.	On-Board Imager Upgrade Option Room Configuration Clinac 2100C/D, 2300C/D, 21EX, 23EX				
	Not For Construction					
OCS.1.1 page	planning dept.	© Varian Medical Systems 2001 All rights reserved.	23Oct07	revision: 1	doc. #: 200047	page OCS.1.1

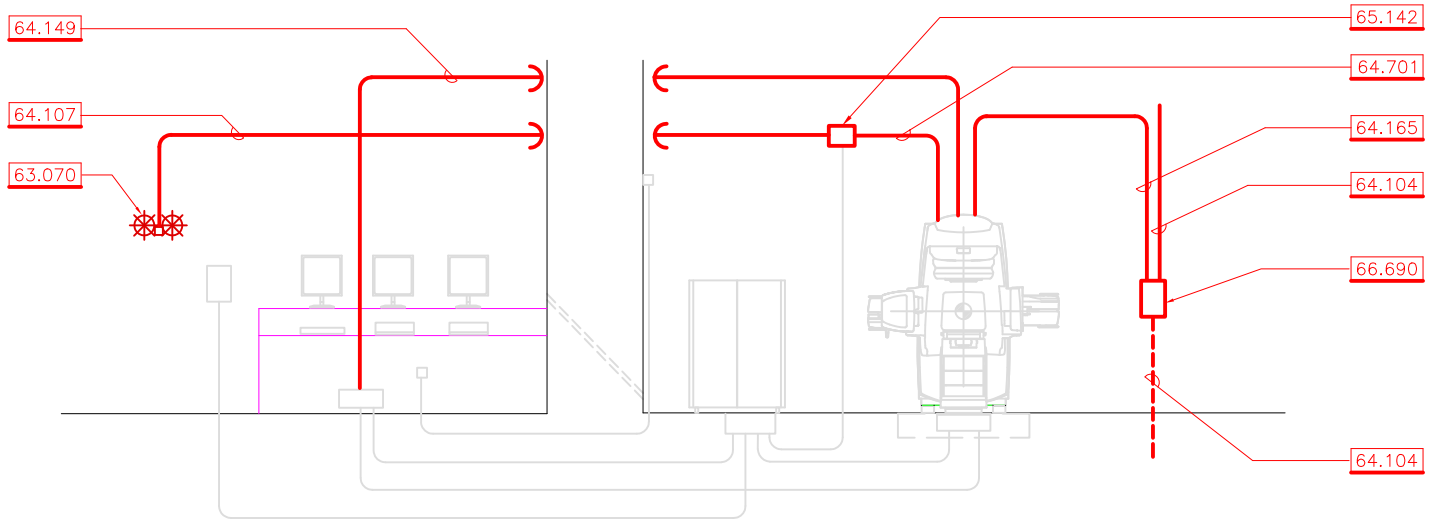

B Typical Conduit Riser 10.691 21.072 64.074

OCS102

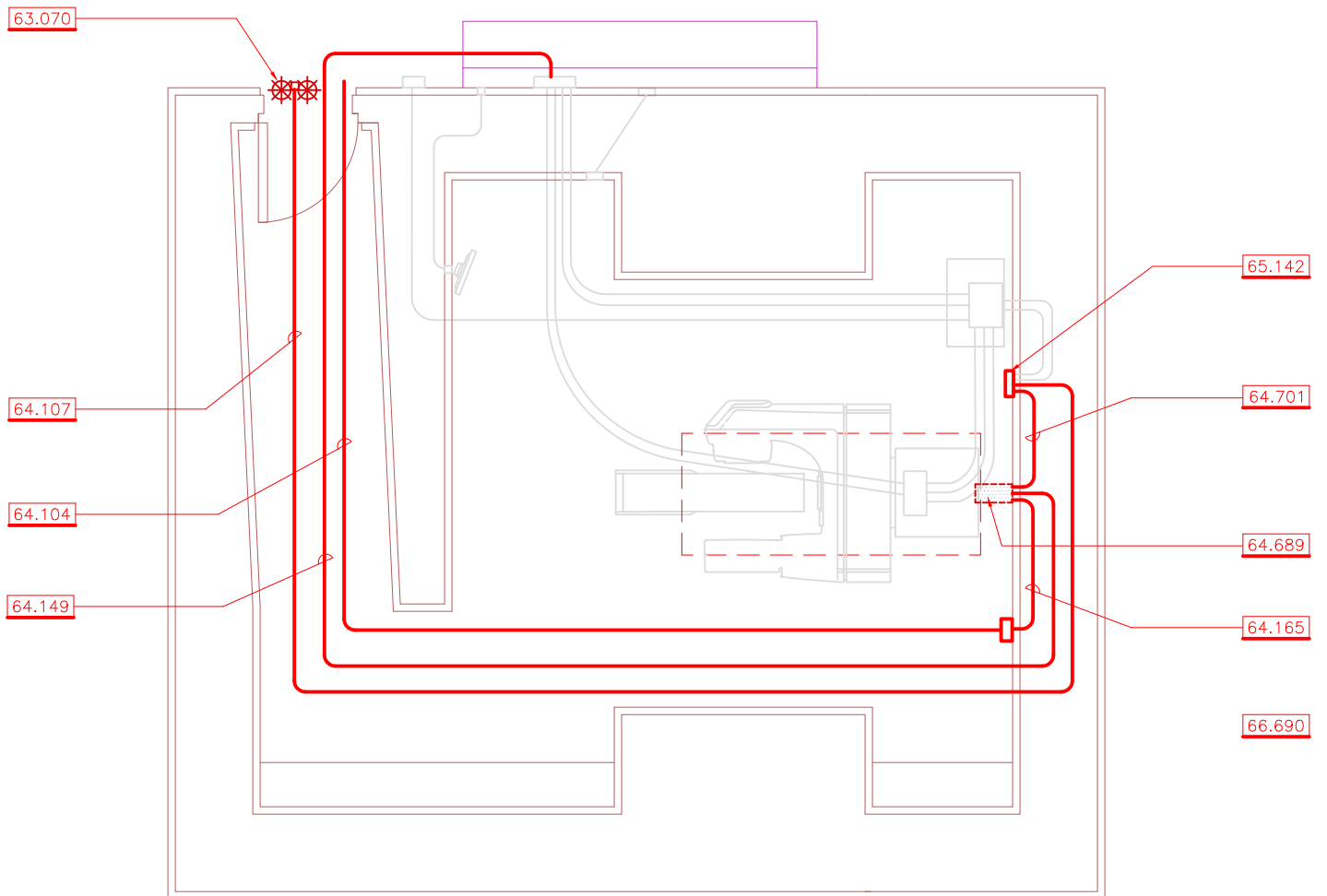

A Typical Cable Run Diagram 10.691 64.074

OCS101

scale at: 1/8"=1'-0"							
		On-Board Imager Upgrade Option Cable Access				Clinac 2100C/(D), 2300C/D, 21EX, 23EX	
		Not For Construction					
OCS.2.0:page	planning dept.	© Varian Medical Systems 2004 All rights reserved.	230ct07	revision: 1	doc. #: 200062	page: OCS.2.0	

10 - General Notes

10.691

All requirements for a standard Clinac 2100C(/D), 2300C/D, 21EX, 23EX, and Silhouette Edition Clinac installation must be met to install the On- Board Imager (OBI) Upgrade option.

Refer to the appropriate Installation Data Package:

- > Section One - Clinac 2100C(/D), 2300C/D, 21EX, 23EX
- > Section Seven - Silhouette Edition Clinac

21 - Equipment Layout / Clearances

21.072

The OBI generator, Interconnect panel and OBI Circuit Breaker panel can be located on either side of the Clinac Stand. If the Modulator is located on one side of the Clinac, the OBI hardware should be located on the opposite side.

63 - Safety Device Systems

63.070

Connections for two warning lights, usually red colored, incandescent (no fluorescent lighting) are provided. Locate over the door, on the outside of the treatment room. They may be required to blink when the x-ray is on. Verify local requirements with regional regulatory agencies.

- > "X-RAY ON" - warning light (maximum 24vdc @250ma)
- > "GENERATOR ON" - warning light (maximum 24vdc @250ma)

The 24vdc @250ma signal can be used to control a Potter - Brumfield PRD11DG0-24, 24 Vdc (or equivalent) relay to switch higher voltage warning lights.

64 - Cable Access Runs

64.074

Verification of appropriate utility and cable access is the responsibility of the Customer. Selection of the appropriate cable access method is determined by site-specific conditions and Customer preference. The standard duct access details are included for installations with minimal subfloor clearance. All conduits or cable ducts must be suitably sealed and protected to keep them clean and dry.

64.104

Provide one 2" (50) conduit between Main Power Feed Panel and OBI Circuit Breaker. This conduit may be installed under slab or run overhead into the treatment room.

64.107

Provide 1/2" (13) conduit between X-RAY warning light(s) and the Relay junction box.

64.149

Varian recommends installation of an additional 4" (100) conduit from the Control Console pull box and the stand. The length of this cable run shall not exceed 75 feet (22,900). Verify existing and additional conduit requirements with Varian Project Manager.

64.165

Provide one 2"(50) conduit between OBI Circuit Breaker and Clinac/Silhouette stand.

- > For new construction, this conduit may be installed under slab and terminated at the Base Frame pull box.
- > For renovations this conduit may be installed overhead and terminated at the Base Frame pull box.

64.689

Provide Conduit/Cable tray between rear wall and Clinac stand.

- > For new Treatment room construction, the Conduit/Cable tray may be installed in the floor slab.
- > For renovation of an existing Treatment room, the conduit /cable tray may be installed on top of the floor slab.

64.701

Provide 1/2" (13) conduit between Relay junction box and the cable tray.

65 - Pull / Junction Boxes

65.142

The Relay junction box shall be 12" x 12" x 6" deep (300 x 300 x 150). Locate box above finished ceiling (if accessible) near the Modulator Cabinet.

66 - Circuit Breakers / UVRs

66.690

The On- Board Imager main circuit breaker panel should be located in the control room or in the treatment room as desired. Verify location requirements with regulatory agencies or local code.

- > Main Circuit Breaker- recommended G.E. Catalog # OBI60A480V (includes 60Amp, three phase 400 - 480V circuit breaker, 60 amp., 480V contactor/120V coil installed in a Lockout/Tagout subpanel) or equivalent. The G.E. Catalog # OBI60A480V information is available from the Planning department web page: varian.com/support or contact your regional Planning Manager.

	[000] Refer to the Varian Components Chart at the end of this section.	On-Board Imager Upgrade Option Cable Access Clinac 2100C/D, 2300C/D, 21EX, 23EX				
	Not For Construction					
OCS.2.1 page	planning dept.	© Varian Medical Systems 2001 All rights reserved.	23Oct07	revision: 1	doc. #: 200062	page: OCS.2.1

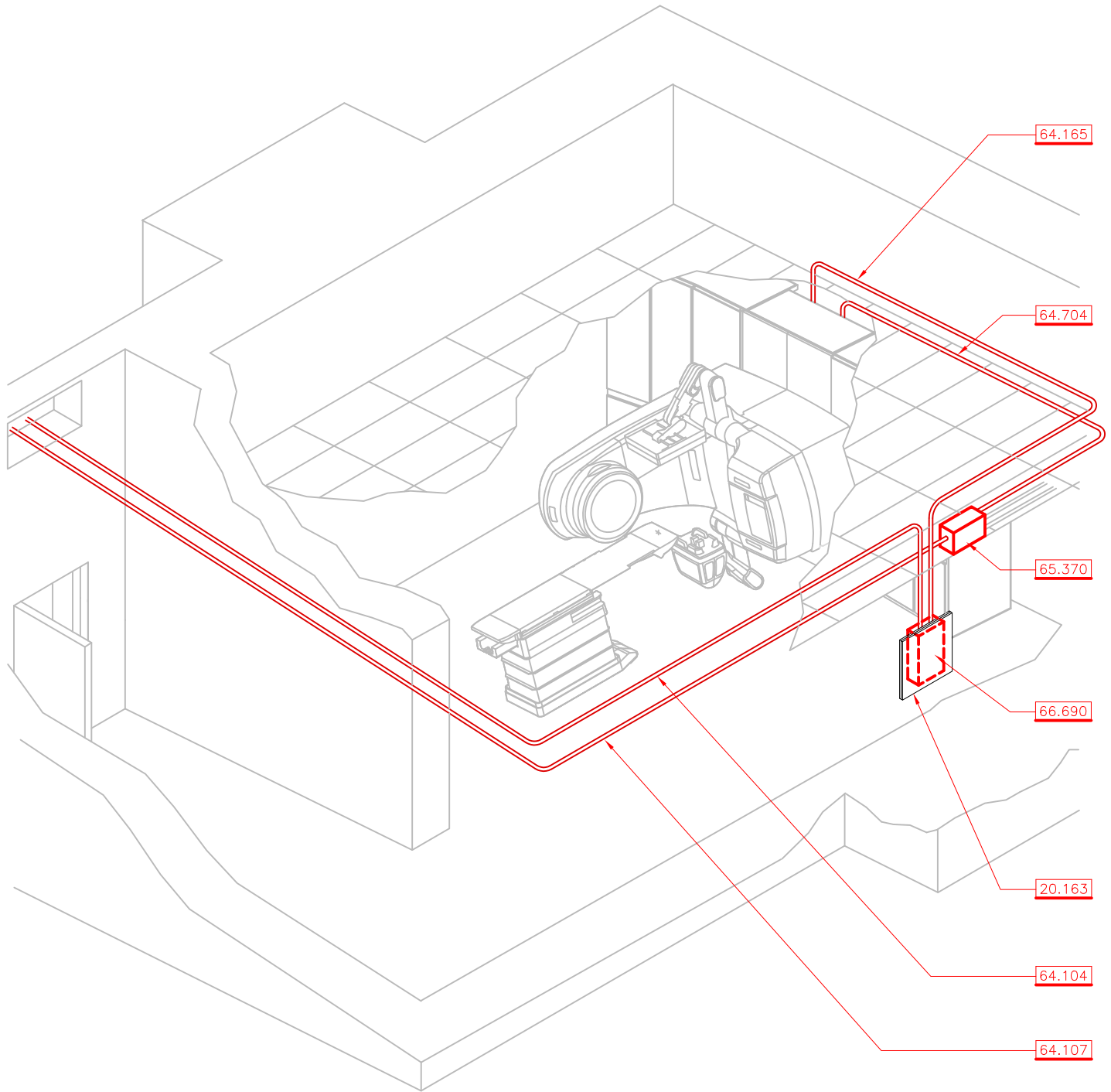

A Typical Room Isometric 10.124 10.691 53.092

OCS103

		On-Board Imager Upgrade Option Room Configuration Silhouette Edition Clinac				
	Not For Construction					
OCS.3.0 :page	planning dept.	© Varian Medical Systems 2004 All rights reserved.	230Oct07	revision: 2	doc. #: 200042	page: OCS.3.0

10 - General Notes

10.124

The layouts shown on IDP drawings represent typical plans only. Clearances and wall thickness may vary.

10.691

All requirements for a standard Clinac 2100C(/D), 2300C/D, 21EX, 23EX, and Silhouette Edition Clinac installation must be met to install the On- Board Imager (OBI) Upgrade option.

Refer to the appropriate Installation Data Package:

> Section One - Clinac 2100C(/D), 2300C/D, 21EX, 23EX

> Section Seven - Silhouette Edition Clinac

20 - General Layout Notes

20.163

The OBI Circuit Breaker Panel may be recessed in the wall. If flush mounted, the Customer/Contractor will provide and install a mounting plate, 24" X 32" X 1" (61cm X 81cm X 2.5cm). Install on the wall and firmly attached to wall studs. The OBI circuit breaker mounting plate should be 48" A.F.F. to the bottom edge of the mounting plate.

53 - Ventilation

53.092

Provide ventilation sufficient for removal of OBI equipment air heat load as follows:

> 1.25 kW (4265 Btu/hr) in the Clinac treatment room for OBI X-Ray on.

> 0.6 kW (2050 Btu/hr) in the Clinac treatment room for OBI standby mode.

> 0.75 kW (2560 Btu/hr) at the Clinac OBI Console

64 - Cable Access Runs

64.104

Provide one 2" (50) conduit between Main Power Feed Panel and OBI Circuit Breaker. This conduit may be installed under slab or run overhead into the treatment room.

64.107

Provide 1/2" (13) conduit between X-RAY warning light(s) and the Relay junction box.

64.165

Provide one 2"(50) conduit between OBI Circuit Breaker and Clinac/Silhouette stand.

> For new construction, this conduit may be installed under slab and terminated at the Base Frame pull box.

> For renovations this conduit may be installed overhead and terminated at the Base Frame pull box.

64.704

Provide 1/2" (13) conduit between Relay junction box and the Silhouette stand.

65 - Pull / Junction Boxes

65.370

The Relay junction box shall be 12" x 12" x 6" deep (300 x 300 x 150). Locate box above finished ceiling and away from the Silhouette cabinet.

66 - Circuit Breakers / UVRs

66.690

The On- Board Imager main circuit breaker panel should be located in the control room or in the treatment room as desired. Verify location requirements with regulatory agencies or local code.

> Main Circuit Breaker- recommended G.E. Catalog # OBI60A480V (includes 60Amp, three phase 400 - 480V circuit breaker, 60 amp., 480V contactor/120V coil installed in a Lockout/Tagout subpanel) or equivalent. The G.E. Catalog # OBI60A480V information is available from the Planning department web page: varian.com/support or contact your regional Planning Manager.

	[000] Refer to the Varian Components Chart at the end of this section.	On-Board Imager Upgrade Option Room Configuration Silhouette Edition Clinac				
	Not For Construction					
OCS.3.1 page	planning dept.	© Varian Medical Systems 2001 All rights reserved.	23Oct07	revision: 2	doc. #: 200042	page: OCS.3.1

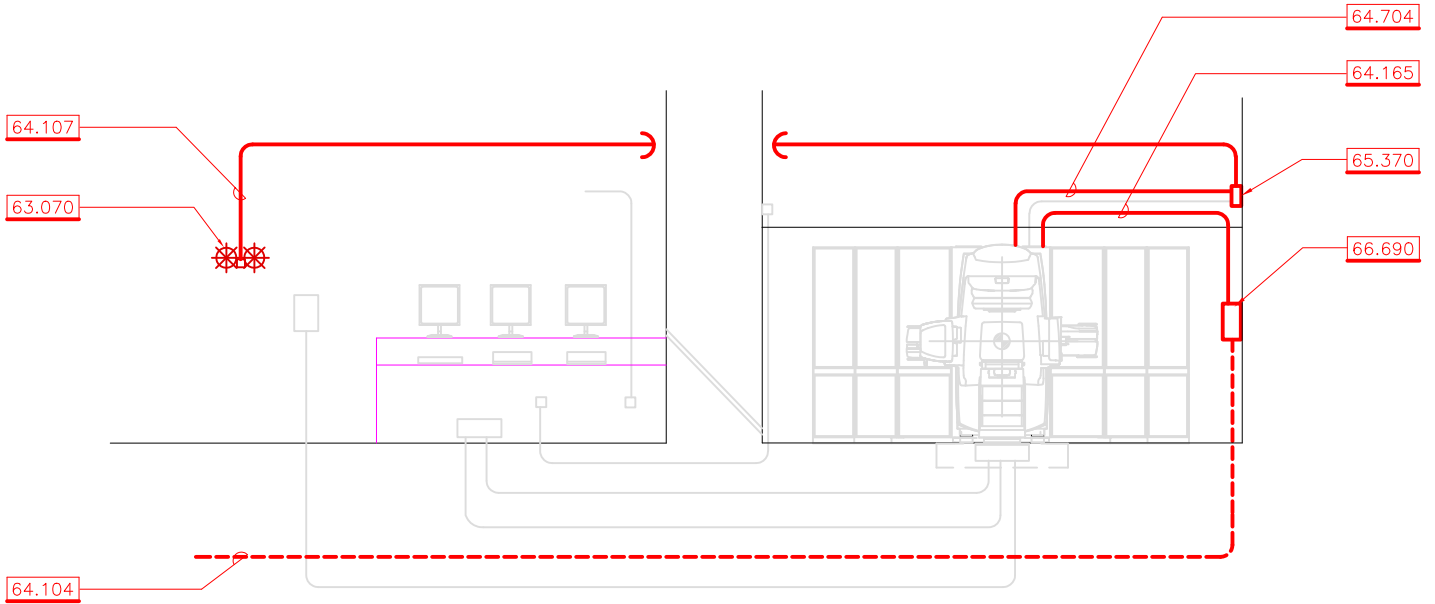

B Typical Conduit Riser 10.691 64.074

OCS105

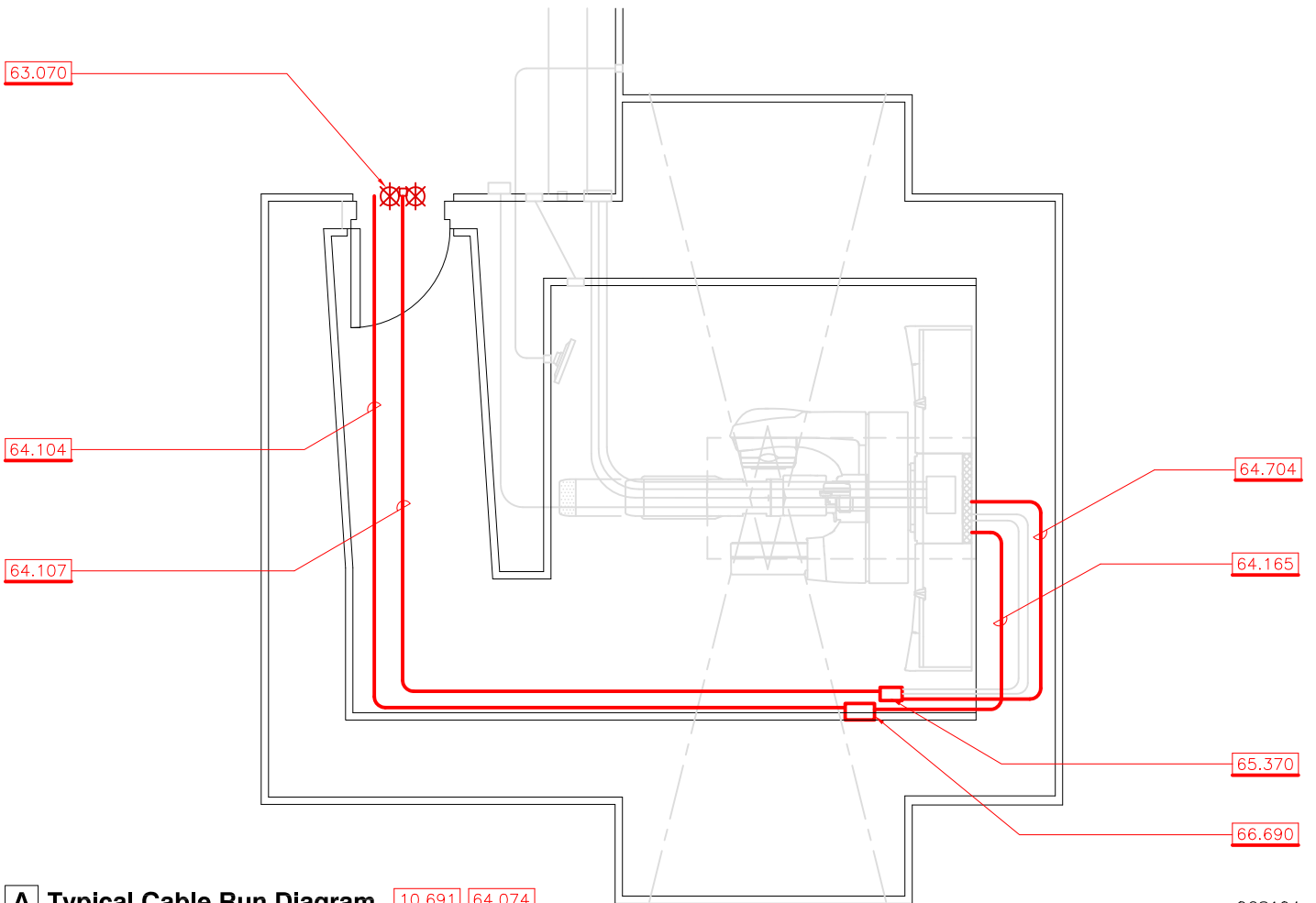

A Typical Cable Run Diagram 10.691 64.074

OCS104

scale at: 1/8"=1'-0"							
	000 Refer to the Varian Components chart at the end of this section.	On-Board Imager Upgrade Option Cable Access Silhouette Edition Clinac					
		Not For Construction					
OCS.4.0:page	planning dept.	© Varian Medical Systems 2004 All rights reserved.	23Oct07	revision: 3	doc. #: 200044	page: OCS.4.0	

10 - General Notes

10.691

All requirements for a standard Clinac 2100C(/D), 2300C/D, 21EX, 23EX, and Silhouette Edition Clinac installation must be met to install the On- Board Imager (OBI) Upgrade option.

Refer to the appropriate Installation Data Package:

- > Section One - Clinac 2100C(/D), 2300C/D, 21EX, 23EX
- > Section Seven - Silhouette Edition Clinac

63 - Safety Device Systems

63.070

Connections for two warning lights, usually red colored, incandescent (no fluorescent lighting) are provided. Locate over the door, on the outside of the treatment room. They may be required to blink when the x-ray is on. Verify local requirements with regional regulatory agencies.

- > "X-RAY ON" - warning light (maximum 24vdc @250ma)
- > "GENERATOR ON" - warning light (maximum 24vdc @250ma)

The 24vdc @250ma signal can be used to control a Potter - Brumfield PRD11DG0-24, 24 Vdc (or equivalent) relay to switch higher voltage warning lights.

64 - Cable Access Runs

64.074

Verification of appropriate utility and cable access is the responsibility of the Customer. Selection of the appropriate cable access method is determined by site-specific conditions and Customer preference. The standard duct access details are included for installations with minimal subfloor clearance. All conduits or cable ducts must be suitably sealed and protected to keep them clean and dry.

64.104

Provide one 2" (50) conduit between Main Power Feed Panel and OBI Circuit Breaker. This conduit may be installed under slab or run overhead into the treatment room.

64.107

Provide 1/2" (13) conduit between X-RAY warning light(s) and the Relay junction box.

64.165

Provide one 2"(50) conduit between OBI Circuit Breaker and Clinac/Silhouette stand.

- > For new construction, this conduit may be installed under slab and terminated at the Base Frame pull box.
- > For renovations this conduit may be installed overhead and terminated at the Base Frame pull box.

64.704

Provide 1/2" (13) conduit between Relay junction box and the Silhouette stand.

65 - Pull / Junction Boxes

65.370

The Relay junction box shall be 12" x 12" x 6" deep (300 x 300 x 150). Locate box above finished ceiling and away from the Silhouette cabinet.

66 - Circuit Breakers / UVRs

66.690

The On- Board Imager main circuit breaker panel should be located in the control room or in the treatment room as desired. Verify location requirements with regulatory agencies or local code.

- > Main Circuit Breaker- recommended G.E. Catalog # OBI60A480V (includes 60Amp, three phase 400 - 480V circuit breaker, 60 amp., 480V contactor/120V coil installed in a Lockout/Tagout subpanel) or equivalent. The G.E. Catalog # OBI60A480V information is available from the Planning department web page: varian.com/support or contact your regional Planning Manager.

	[000] Refer to the Varian Components Chart at the end of this section.	On Board Imager Upgrade Option Cable Access Silhouette Edition Clinac				
	Not For Construction					
OCS.4.1 page	planning dept.	© Varian Medical Systems 2001 All rights reserved.	23Oct07	revision: 3	doc. #: 200044	page:OCS.4.1

OBI Components							
Key	Equipment	Height inch (mm)	Width inch (mm)	Depth inch (mm)	Weight lb (kg)	Max Watts	Max dbA
022	Workstation Computer	19 (483)	8 (203)	17 (432)	27 (12)	240	n/a
023	Workstation Monitor	20 (508)	22 (559)	4 (102)	18 (8)	n/a	25
080	Control Foot Switch	5 (127)	6 (152)	6 (152)	6.1 (3)	n/a	n/a
088	PaxScan Image Command Processor	5.5 (140)	11 (279)	12.5 (318)	16 (7)	n/a	n/a
170	4D-Integrated Treatment Console	2 (51)	11.8 (300)	13.7 (348)	5 (2)	n/a	n/a

OCS109

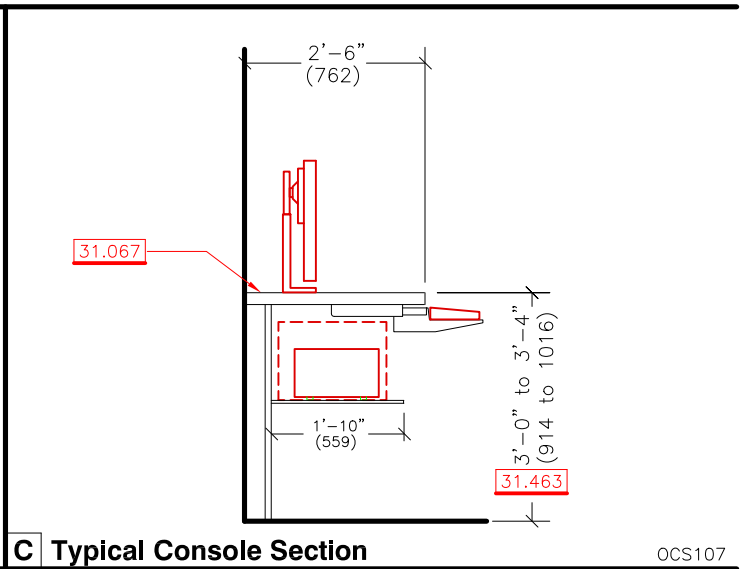
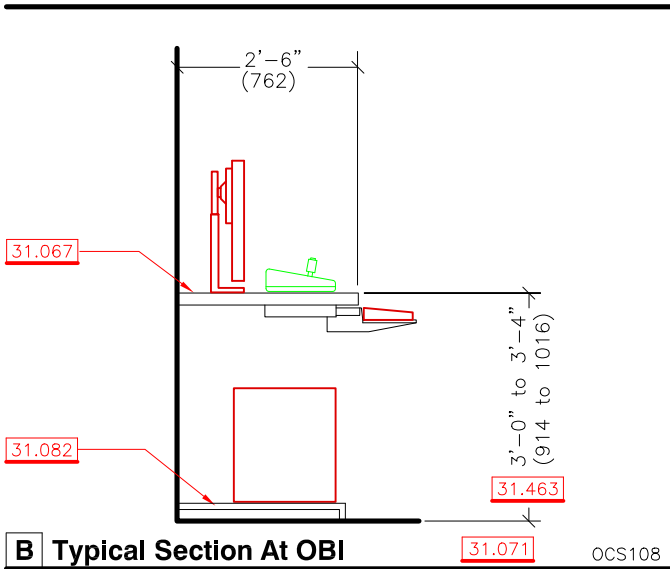

B Typical Section At OBI

OCS108

C Typical Console Section

OCS107

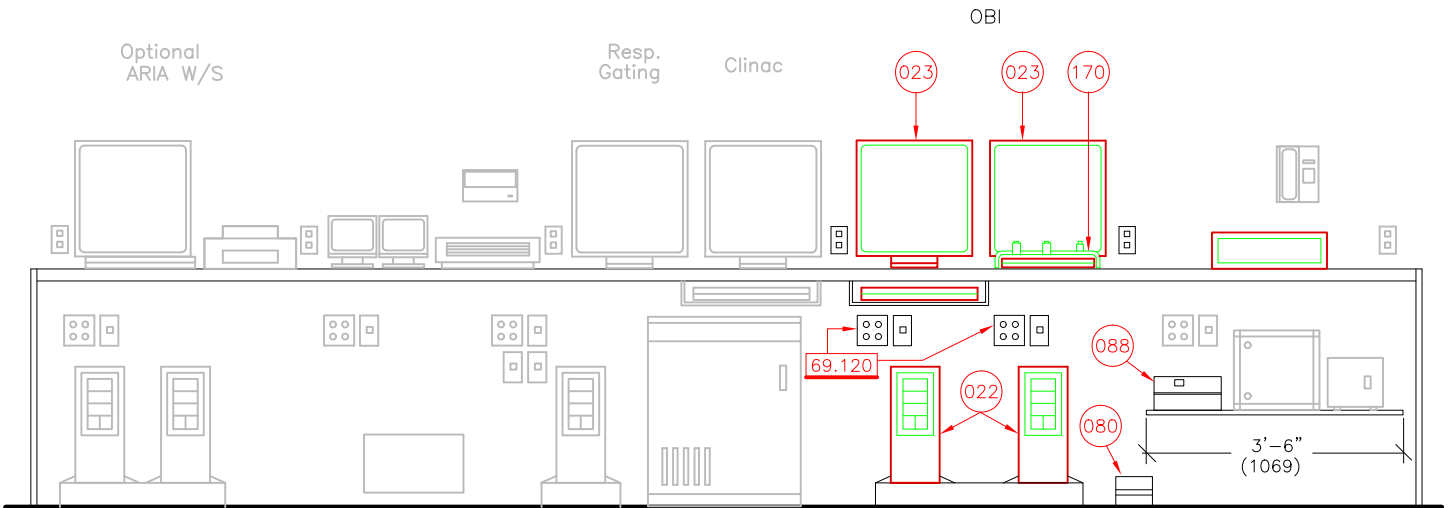

A Typical Control Console Equipment

10.691 21.073 30.024 31.084 53.092

OCS106

scale at: 3/8" = 1'-0"

		On-Board Imager Upgrade Option Console Casework Clinac 2100C/D, 2300C/D, 21EX, 23EX, Silhouette				
	Not For Construction					
OCS.5.0 :page	planning dept.	© Varian Medical Systems 2004 All rights reserved.	230oct07	revision: 1	doc. #: 200043	page: OCS.5.0

10 - General Notes

10.691

All requirements for a standard Clinac 2100C(/D), 2300C/D, 21EX, 23EX, and Silhouette Edition Clinac installation must be met to install the On- Board Imager (OBI) Upgrade option.

Refer to the appropriate Installation Data Package:

- > Section One - Clinac 2100C(/D), 2300C/D, 21EX, 23EX
- > Section Seven - Silhouette Edition Clinac

21 - Equipment Layout / Clearances

21.073

The On-Board Imager (OBI) x-ray system is an optional accessory to the Clinac high-energy accelerator used for patient positioning and provides high-resolution digital images for target localization.

30 - Finishes

30.024

As with most computer components, the electronic components for this equipment are sensitive to localized static electricity. Carpeting or other flooring adjacent to the equipment in the room or at the control equipment area should not exceed a 2.0 kV rating at 20% relative humidity when measured as outlined by the methods in AATCC-134. Retrofit static dissipative coatings are also available from various manufacturers. Carpet, while otherwise advantageous, can make gurney movement difficult. Floor stains are common due to the use of dyes to mark reference points on patients. Many facilities use carpet squares that can be replaced or cleaned and allow access to floor duct if used.

31 - Control Equipment Casework

31.067

Provide 3"(75) diameter grommets holes as required at counter and shelf for cables (typical). If possible, in order to accommodate on-site Customer preferences and possible changes in equipment configuration, locate and drill holes after the control equipment has been arranged on location. A gap or slots at the back of the counter and shelf for cable access is also acceptable.

31.071

Provide a minimum 3"(75) air and cable space at sides, top and rear of all computers and monitors.

31.082

Provide minimum 4"(100) high platform at computers under the counter to prevent damage. The flooring may be covered up the platform edge for ease of cleaning. Verify under counter clearance height. Where space permits, these components may be located on the counter.

31.084

This control equipment casework design is provided as a suggestion for possible component arrangement only. The shelf and counter design shown is recommended because it allows for final component placement adjustments on site to suit personal preference and can accommodate future equipment upgrades and additional options. Optional equipment is often added after the Clinac or Acuity has been installed and should be planned for even if they are not part of the initial order. The control equipment location should be as close to the treatment room door as possible to provide control over the entrance and reduce the travel distance. CCTV, cabinetry, intercom and phones are Customer-supplied items, shown on Varian drawings for illustrative purposes only. It is often desirable to locate the control equipment facing in a direction that allows the therapists to visually control the adjacent area. This layout can also reduce the visibility of CCTV monitors for patient privacy.

31.463

The recommended counter height range shown assumes that the therapists are standing or using stools during typical treatment cycles. Some facilities provide areas at the control area designed for chair height. Adjust dimensions at these areas as required.

53 - Ventilation

53.092

Provide ventilation sufficient for removal of OBI equipment air heat load as follows:

- > 1.25 kW (4265 Btu/hr) in the Clinac treatment room for OBI X-Ray on.
- > 0.6 kW (2050 Btu/hr) in the Clinac treatment room for OBI standby mode.
- > 0.75 kW (2560 Btu/hr) at the Clinac OBI Console

69 - Power Receptacles / Switches

69.120

Provide two grounded 4 plex electrical power receptacles for Trilogy/OBI option components. Locate adjacent to the underside of the counter to provide maximum power cable extension.

	[000] Refer to the Varian Components Chart at the end of this section.	On-Board Imager Upgrade Option Console Casework				
	Not For Construction	Clinac 2100C/D, 2300C/D, 21EX, 23EX, Silhouette				
OCS.5.1 page	planning dept.	© Varian Medical Systems 2001 All rights reserved.	23Oct07	revision: 1	doc. #: 200043	page:OCS.5.1

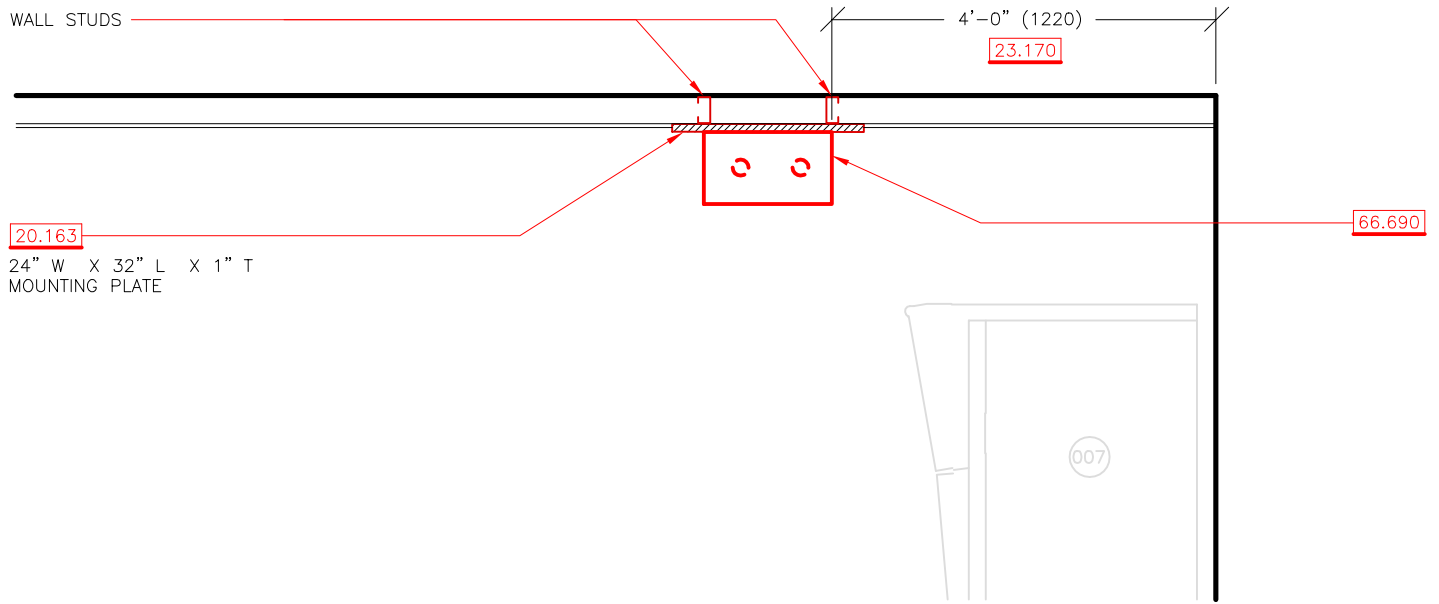

B Main Circuit Breaker Panel - Detail Plan

OCS111

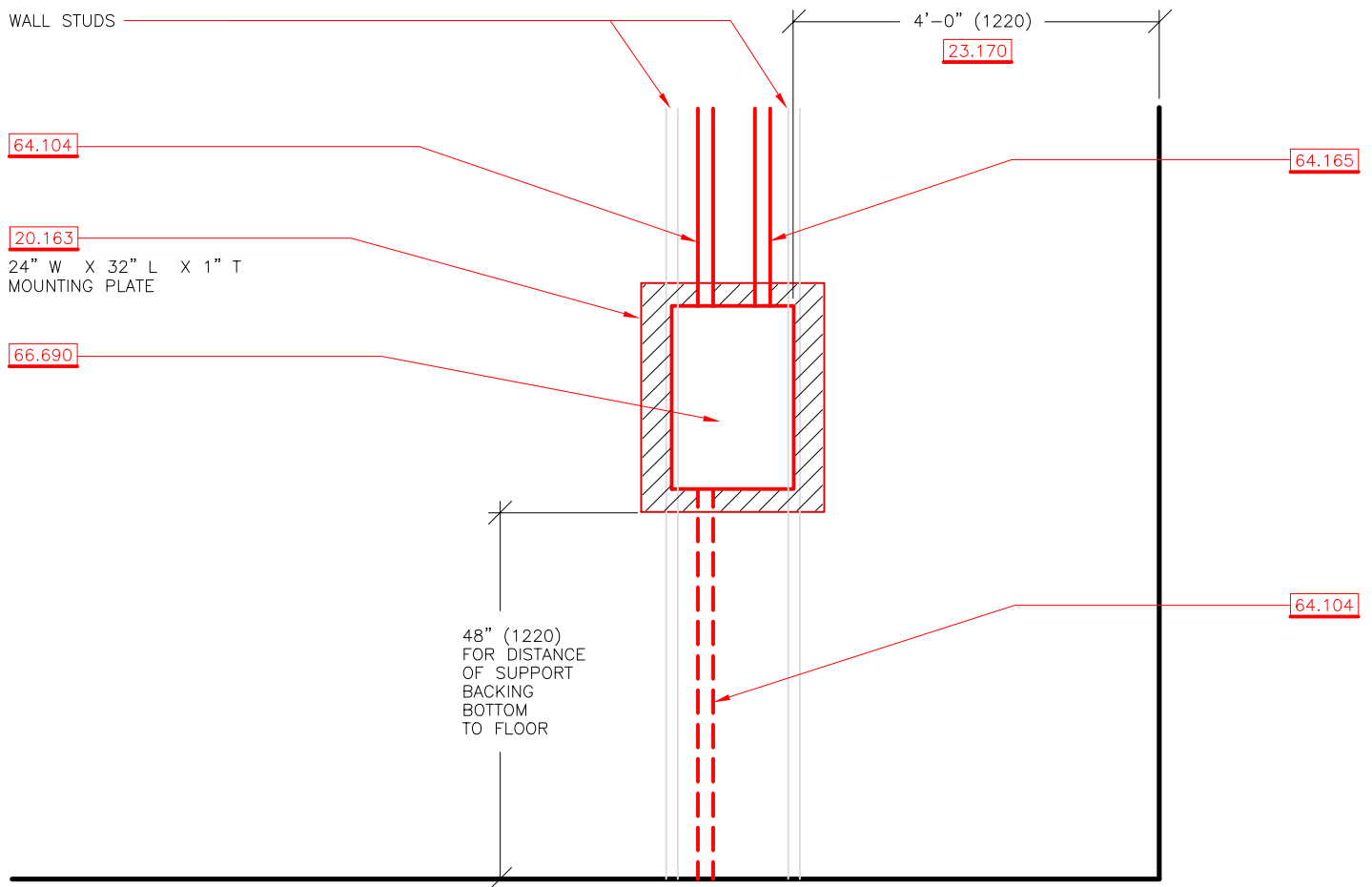

A Main Circuit Breaker Panel - Detail Elevation

10.691 60.154 64.074

OCS110

scale at:	1/2"=1'-0"						
		On-Board Imager Upgrade Option Main Power Panel Clinac 2100C/D, 2300C/D, 21EX, 23EX, Silhouette					
		Not For Construction					
OCS.6.0:page	planning dept.	© Varian Medical Systems 2004 All rights reserved.	01Aug06	revision: 0	doc. #: 200045	page: OCS.6.0	

10 - General Notes

10.691

All requirements for a standard Clinac 2100C(/D), 2300C/D, 21EX, 23EX, and Silhouette Edition Clinac installation must be met to install the On- Board Imager (OBI) Upgrade option.

Refer to the appropriate Installation Data Package:

- > Section One - Clinac 2100C(/D), 2300C/D, 21EX, 23EX
- > Section Seven - Silhouette Edition Clinac

20 - General Layout Notes

20.163

The OBI Circuit Breaker Panel may be recessed in the wall. If flush mounted, the Customer/Contractor will provide and install a mounting plate, 24" X 32" X 1" (61cm X 81cm X 2.5cm). Install on the wall and firmly attached to wall studs. The OBI circuit breaker mounting plate should be 48" A.F.F. to the bottom edge of the mounting plate.

23 - Dimension Descriptions

23.170

This is the recommended minimum dimension from the back wall to the edge of the OBI Circuit Breaker Panel.

60 - General Electrical Specifications

60.154

Power Conditioning Requirements

- > The equipment is sensitive to line voltage variations and source impedance. A complete survey of the electrical supply should be conducted prior to the equipment installation. Isolation transformers and/or power conditioners are required where the electrical power requirements specified herein cannot be met.
- > Caution should be taken when powering the x-ray equipment from the same distribution source such as elevators, HVAC equipment and other phase controlled loads, because of potential adverse affects on the operation of the x-ray equipment. The supply voltage wave form should be practically sinusoidal with less than 5% total harmonic distortion. Signals from devices that use the power line as a means of distribution can be the source of problems, and efforts should be taken to minimize such effects.
- > Transient suppression is required where larger, longer lasting or frequent transients occur as these can cause interruption of operation and/or equipment damage.

64 - Cable Access Runs

64.074

Verification of appropriate utility and cable access is the responsibility of the Customer. Selection of the appropriate cable access method is determined by site-specific conditions and Customer preference. The standard duct access details are included for installations with minimal subfloor clearance. All conduits or cable ducts must be suitably sealed and protected to keep them clean and dry.

64.104

Provide one 2"(50) conduit between Main Power Feed Panel and OBI Circuit Breaker. This conduit may be installed under slab or run overhead into the treatment room.

64.165

Provide one 2"(50) conduit between OBI Circuit Breaker and Clinac/Silhouette stand.

- > For new construction, this conduit may be installed under slab and terminated at the Base Frame pull box.
- > For renovations this conduit may be installed overhead and terminated at the Base Frame pull box.

66 - Circuit Breakers / UVRs

66.690

The On- Board Imager main circuit breaker panel should be located in the control room or in the treatment room as desired. Verify location requirements with regulatory agencies or local code.

- > Main Circuit Breaker- recommended G.E. Catalog # OBI60A480V (includes 60Amp, three phase 400 - 480V circuit breaker, 60 amp., 480V contactor/120V coil installed in a Lockout/Tagout subpanel) or equivalent. The G.E. Catalog # OBI60A480V information is available from the Planning department web page: varian.com/support or contact your regional Planning Manager.

	[000] Refer to the Varian Components Chart at the end of this section.	On Board Imager Upgrade Option Main Power Panel Clinac 2100C/D, 2300C/D, 21EX, 23EX, Silhouette			
	Not For Construction	01Aug06	revision: 0	doc. #: 200045	page: OCS.6.1
OCS.6.1 page	planning dept.	© Varian Medical Systems 2001 All rights reserved.			

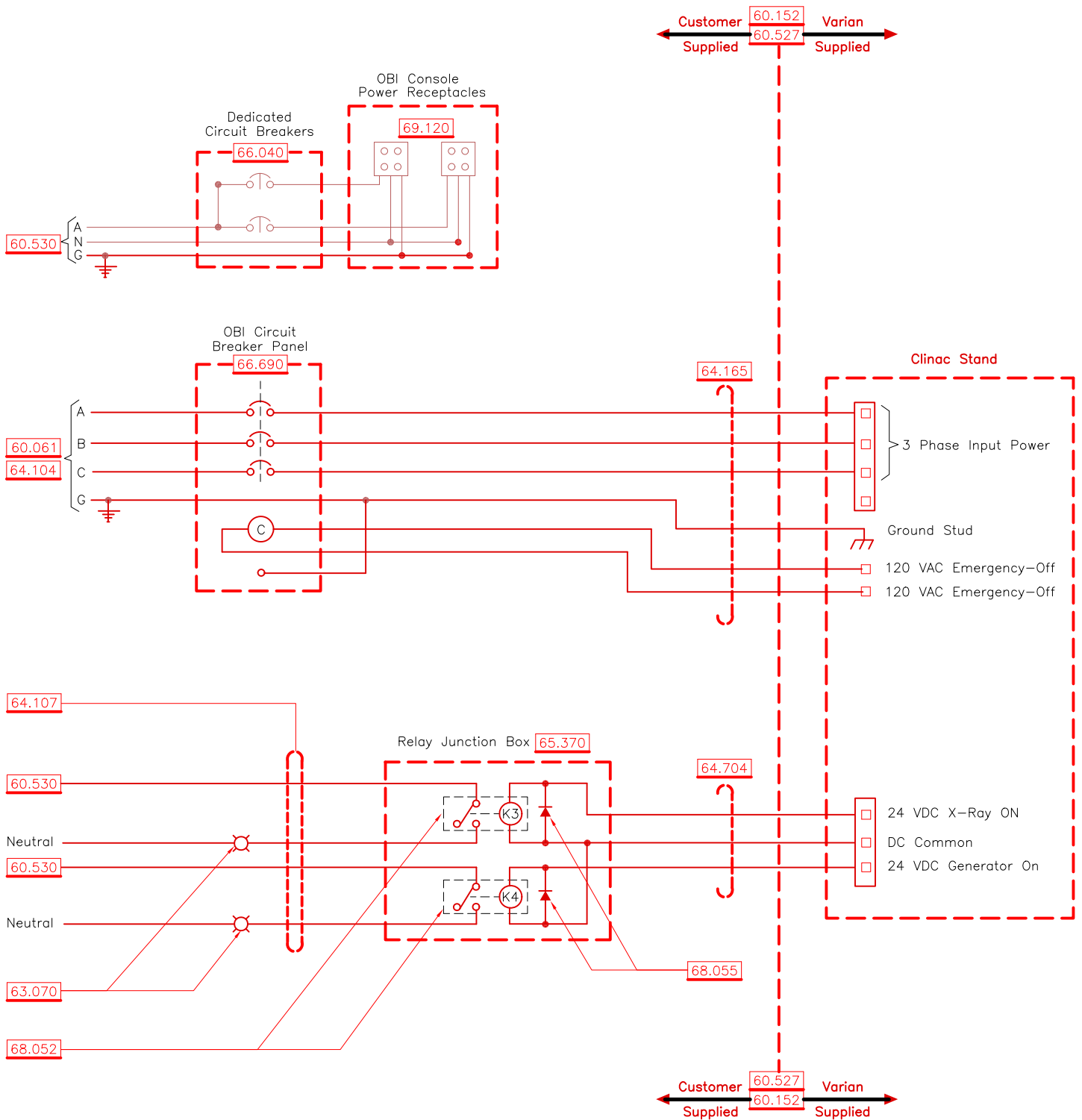

10.691 60.154

OCS112

	Refer to the Varian Components chart at the end of this section.	On-Board Imager Upgrade Option Wiring Diagram Clinac 2100C/D, 2300C/D, 21EX, 23EX, Silhouette			
	Not For Construction				
OCS.7.0 :page	planning dept.	© Varian Medical Systems 2004 All rights reserved.	230Oct07	revision: 3	doc. #: 200046
					page: OCS.7.0

10 - General Notes

10.691

All requirements for a standard Clinac 2100C(D), 2300C/D, 21EX, 23EX, and Silhouette Edition Clinac installation must be met to install the On- Board Imager (OBI) Upgrade option.

Refer to the appropriate Installation Data Package:

- > Section One - Clinac 2100C(D), 2300C/D, 21EX, 23EX
- > Section Seven - Silhouette Edition Clinac

60 - General Electrical Specifications

60.061

On- Board Imager option Power Requirements

- > Input voltage - 400 to 480 Vac ($\pm 10\%$) 4 wire, 3-phase and ground.
- > Input frequency - 50 or 60 Hz $\pm 1\%$
- > Maximum phase voltage imbalance not to exceed 2% of the nominal value. This is the maximum difference between any two-phase voltages when operating at full load.
- > The maximum allowable momentary line voltage variation due to causes other than the x-ray equipment load shall not exceed $\pm 2.5\%$.
- > Maximum input impedance: 0.10 Ohm at 400 to 480 Vac.
- > Power On/Quiescence state - 1.0 kVA.
- > Supply capacity - 60 kVA.
- > Ground equipment through the "Hospital grid system" (The equipment is sensitive to electrolysis from water pipe grounding). Do not use water supply piping for grounding!
- > A grounding copper cable, minimum conductor size of not less than 2 AWG (35mm²), originating at the hospital main ground.

60.152

On-Board Imager (OBI) or Trilogy Electrical Connections - The Customer shall:

- > Supply and connect phase, earth/ground power supply wires, under Varian supervision, to the H.F. Generator cabinet [083] per the Interconnection Wiring Diagram.
- > Review connections and equipment function with Varian Installer.
- > Insure that rough-in for conductors for listed items includes 10 feet (3 M) left coiled in the Base Frame pull box.
- > Provide conductors and conduit from an isolated power source through Main Circuit Breaker panel.
- > Supply and connect phase, and earth/ground power supply wires.
- > Supply and connect conduit and wiring for Warning Lights.
- > Bundle all wiring in cable trays shared by Varian cables.
- > Pull Varian-supplied cables.

60.154

Power Conditioning Requirements

- > The equipment is sensitive to line voltage variations and source impedance. A complete survey of the electrical supply should be conducted prior to the equipment installation. Isolation transformers and/or power conditioners are required where the electrical power requirements specified herein cannot be met.
- > Caution should be taken when powering the x-ray equipment from the same distribution source such as elevators, HVAC equipment and other phase controlled loads, because of potential adverse effects on the operation of the x-ray equipment. The supply voltage wave form should be practically sinusoidal with less than 5% total harmonic distortion. Signals from devices that use the power line as a means of distribution can be the source of problems, and efforts should be taken to minimize such effects.
- > Transient suppression is required where larger, longer lasting or frequent transients occur as these can cause interruption of operation and/or equipment damage.

60.527

The Customer shall provide all wiring and components shown on the left side of the terminal blocks. Varian shall provide all circuits to the right of the terminal blocks. The Varian-provided control interconnect cables are not shown on this drawing.

60.530

Provide 120 Vac (typical 60Hz) or 240 Vac (typical 50Hz) power.

63 - Safety Device Systems

63.070

Connections for two warning lights, usually red colored, incandescent (no fluorescent lighting) are provided. Locate over the door, on the outside of the treatment room. They may be required to blink when the x-ray is on. Verify local requirements with regional regulatory agencies.

- > "X-RAY ON" - warning light (maximum 24vdc @250ma)
 - > "GENERATOR ON" - warning light (maximum 24vdc @250ma)
- The 24vdc @250ma signal can be used to control a Potter - Brumfield PRD11DG0-24, 24 Vdc (or equivalent) relay to switch higher voltage warning lights.

64 - Cable Access Runs

64.104

Provide one 2" (50) conduit between Main Power Feed Panel and OBI Circuit Breaker. This conduit may be installed under slab or run overhead into the treatment room.

64.107

Provide 1/2" (13) conduit between X-RAY warning light(s) and the Relay junction box.

64.165

Provide one 2"(50) conduit between OBI Circuit Breaker and Clinac/Silhouette stand.

- > For new construction, this conduit may be installed under slab and terminated at the Base Frame pull box.
- > For renovations this conduit may be installed overhead and terminated at the Base Frame pull box.

64.704

Provide 1/2" (13) conduit between Relay junction box and the Silhouette stand.

65 - Pull / Junction Boxes

65.370

The Relay junction box shall be 12" x 12" x 6" deep (300 x 300 x 150). Locate box above finished ceiling and away from the Silhouette cabinet.

66 - Circuit Breakers / UVRs

66.040

Provide 15 amp at 120 Vac or 15 amp at 240 Vac dedicated circuit breakers for Varian control console equipment power outlets.

66.690

The On- Board Imager main circuit breaker panel should be located in the control room or in the treatment room as desired. Verify location requirements with regulatory agencies or local code.

- > Main Circuit Breaker- recommended G.E. Catalog # OBI60A480V (includes 60Amp, three phase 400 - 480V circuit breaker, 60 amp., 480V contactor/120V coil installed in a Lockout/Tagout subpanel) or equivalent. The G.E. Catalog # OBI60A480V information is available from the Planning department web page: varian.com/support or contact your regional Planning Manager.

68 - Misc Electrical Components

68.052

Provide box mounted control relay: Potter - Brumfield PRD11DG0-24, 24 Vdc (or equivalent). The maximum current through this relay is 20 amps per contact for fluorescent tubes and 10 amps per contact for incandescent lighting. These ratings apply at voltages up to 277 Vac. The UL-recognized life under this rated load is 6,000 cycles. The current rating cannot be doubled simply by using this relay in parallel. If higher load lighting is used, this relay must be used to control larger relays or different relays must be specified. The maximum total coil current at the relay is 1 amp.

68.055

Provide a Diode (1N4001 or equivalent), reverse biased, at the relay.



[000] Refer to the Varian Components Chart at the end of this section.

Not For Construction

© Varian Medical Systems 2001
All rights reserved.

**On Board Imager Upgrade Option Wiring Diagram
Clinac 2100C/D, 2300C/D, 21EX, 23EX, Silhouette**

23Oct07

revision: **3**

doc. #: **200046**

page:**OCS.7.1**

OCS.7.1 page

planning
dept.

69 - Power Receptacles / Switches

69.120

Provide two grounded 4 plex electrical power receptacles for Trilogy/OBI option components. Locate adjacent to the underside of the counter to provide maximum power cable extension.

VARIAN medical systems	[000] Refer to the Varian Components Chart at the end of this section.	On Board Imager Upgrade Option Wiring Diagram Clinac 2100C/D, 2300C/D, 21EX, 23EX, Silhouette				
	Not For Construction					
OCS.7.2 page	planning dept.	© Varian Medical Systems 2001 All rights reserved.	23Oct07	revision: 3	doc. #: 200046	page: OCS.7.2

On-Board Imager (OBI) Upgrade Pre-Installation Checklist

In accordance with current Varian "Standard Terms and Conditions of Sale" RAD 1652, para. 15 & 16, the following are the minimum facility requirements to be accomplished before the upgrade device can be released for shipment. Requests for any exceptions should be referred to your Varian Regional Installation Project Manager. The Customer is responsible for having the building, utilities, lighting, ventilation, air conditioning, mounting facilities, all necessary radiation shielding, and access to the room completed by the day of final inspection. (If delays in completion delay installation, the Customer shall reimburse Varian, at Varian's standard service rates, for any extra time and /or travel by Varian made necessary by the delay). I have explained these requirements to the Customer on this date along with the specific requirements listed below.

Varian Representative	Date	Customer Representative	Date
-----------------------	------	-------------------------	------

Site	Equipment Type	Serial Number
------	----------------	---------------

Y N OBI UPGRADE REQUIREMENTS:

- 1. All specifications and requirements for a High Energy Clinac have been met, 21xx, 23xx, Silhouette, and iX.
- 2. Copy of kV X-Ray Imaging License.
- 3. Power Conditioner installed (if applicable).
- 4. 480 VAC, 60A, 60 (or 50) Hz wiring pulled and tested (3-phase, neutral, and ground).
- 5. One 2" (50) conduit installed between Main Power Feed panel and OBI Circuit Breaker.
- 6. Verify sufficient ventilation for heat removal of OBI system.
- 7. OBI Interconnect cables on site.
- 8. Existing conduits between Stand and Console are verified by Varian Service/Installation for additional OBI cabling. Conduits must be clean and dry.
- 9. "X-Ray On" and "Generator On" warning light(s) installed and one ½" (13) conduit installed between warning light(s) and the relay junction box.
- 10. Additional relay for each warning light installed in relay junction box.
- 11. Riggers contracted to assist with imaging arm installation (Optional - 2 days work).

Y N CLINAC TREATMENT ROOM:

- 12. Interconnect Panel mounting plate installed, and not within primary beam of Clinac. **Dedicated Generator ONLY.**
- 13. Cable tray (min. 3 ½" x 10" [89x254]) with one divider installed between HV Generator cabinet and Clinac Stand. Cable tray linear length cannot exceed 16' 0" (4,877). **Dedicated Generator ONLY.**
- 14. Cable tray (min. 3 ½" x 10" [89x254]) with one divider installed between the floor tray and the Interconnect Panel. **Dedicated Generator ONLY.**
- 15. OBI circuit breaker (preferably GE OBI60A480V) mounted on wall mounting plate.
- 16. One 2" (50) flexible conduit installed between OBI Circuit Breaker and H.F. cabinet. **Dedicated Generator ONLY.**
- 17. One 2" (50) conduit installed between OBI Circuit Breaker and Baseframe Pull-box. **Integrated Generator ONLY.**

NOTES: _____

Y N SILHOUETTE TREATMENT ROOM (ONLY):

- 19. OBI circuit breaker (preferably GE OBI60A480V) mounted on wall mounting plate.
- 20. One 2" (50) conduit installed between OBI Circuit Breaker and Silhouette cabinet/Stand.
- 21. One ½" (13) conduit installed between X-RAY warning light(s) and the relay junction box.

Y N CONTROL EQUIPMENT AREA:

- 22. Verify two grounded 4-plex electrical power receptacles available for OBI option components.
- 23. Verify sufficient space for additional computer equipment.
- 24. Clinac console v7.0 upgrade completed, or planned in conjunction with OBI install.
- 25. VARiS, Aria or 3rd-Party R/V upgrade completed, or planned in conjunction with OBI install.
- 26. MLC v6.8 upgrade completed, or planned in conjunction with OBI install.
- 27. High-speed internet access available.
- 28. Verify sufficient ventilation for heat removal of additional computer equipment.

Y N OTHER:

- 29. Inform Applications of Installation Rig Dates.
- 30. MICAP survey completed and posted.
- 31. Respiratory gating installed, or planned in conjunction with OBI install.
- 32. Exact Arm PV installed, or upgrade to PV installed, or planned in conjunction with OBI install.
- 33. OBI Interconnect cables on site.
- 34. Riggers contracted to move OBI hardware into the room, set in place, and assist in assembling major components (if required).
- 34. Film processor available for use in Clinac area.
- 35. Provisions made for approximately 50 sq.ft. secure storage.
- 36. Provisions made for removal of shipping crates, boxes and packing material.
- 37. Qualified physicist scheduled for preliminary radiation survey, as needed.
- 38. Qualified physicist and dosimeter calibration equipment available for acceptance testing, as needed.

Varian Representative	Customer Representative	Date
-----------------------	-------------------------	------

g OBI Circuit Breaker Panel

Application

The On-Board Imager (OBI) Circuit breaker panel is a custom panel, which serves as the main power, disconnect between the x-ray system and the facility 480V power source. The panel provides emergency shut down and overcurrent protection for the x-ray system.

The standardized design provides a platform for future upgrades of the system. The panel offers the customer and the installer a number of advantages by combining a variety of individual components into a single pre-engineered and factory tested panel. Each panel is UL and cUL listed for compliance with NEC Article 100 and Article 110-3. The main breaker panel includes a power contactor for connection and control of the Varian Clinac High Energy Accelerator system, providing immediate shut down of the OBI system to comply with NEC required disconnecting means. The panel may be surface or semi-flush mounted.

Standard Applications

Varian OBI - Systems in conjunction with Varian Clinac High Energy Accelerators.

Benefits

- Developed specifically for use with Varian Oncology Systems.
- Reduces installation time and cost by providing a single-point power connection eliminating the need to mount and wire a number of individual components.
- Standardized design provides for pre-engineered system modifications such as uninterruptible power supply.
- Uniform factory design eliminates individual project engineering costs, and delays of on site fabrication.
- Main power contactor is coordinated to interface with system emergency off.
- UL and cUL listed to conform to local codes minimizing inspection and acceptance issues.
- Standardized design and testing assures high product quality and system reliability.
- Single panel provides for a more attractive, color coordinated installation.

Features

- Single panel completely assembled and tested.
- Custom wiring diagram speeds installation.
- UL and cUL listed to conform to NEC.
- Complies with NEC Article 100 Definition of Approved and Article 110-3 Approved.
- Provides low voltage, 120V controlled contactor operation.
- High interrupting solid-state 25,000 AIC-480V rated, molded case breakers with adjustable instantaneous trip.

- Padlocking provisions for OSHA lockout/tag out included on individual main breaker handle.
- Cover may be locked closed with door and hasp or customer provided padlock.
- ¼ turn slotted door latch provides additional security.
- Isolated neutral lugs.
- Oversized ground lugs for parity sizing of ground wire.
- Ground bus bar for control circuit ground wires.
- All devices selected for high reliability and long life.
- Finger safe terminal blocks for control circuit connections.
- Surface or semi-flush mounting.
- Custom tailored for Varian X-ray Systems with Clinac High Energy Accelerator.



g OBI Circuit Breaker Panel

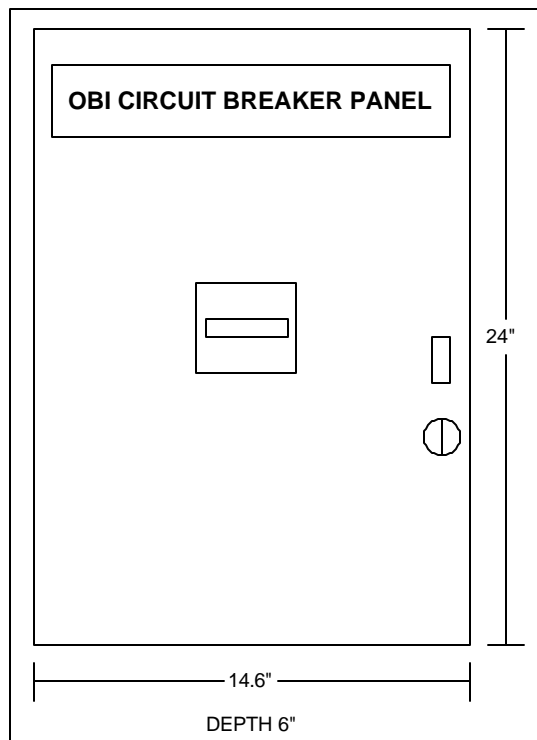
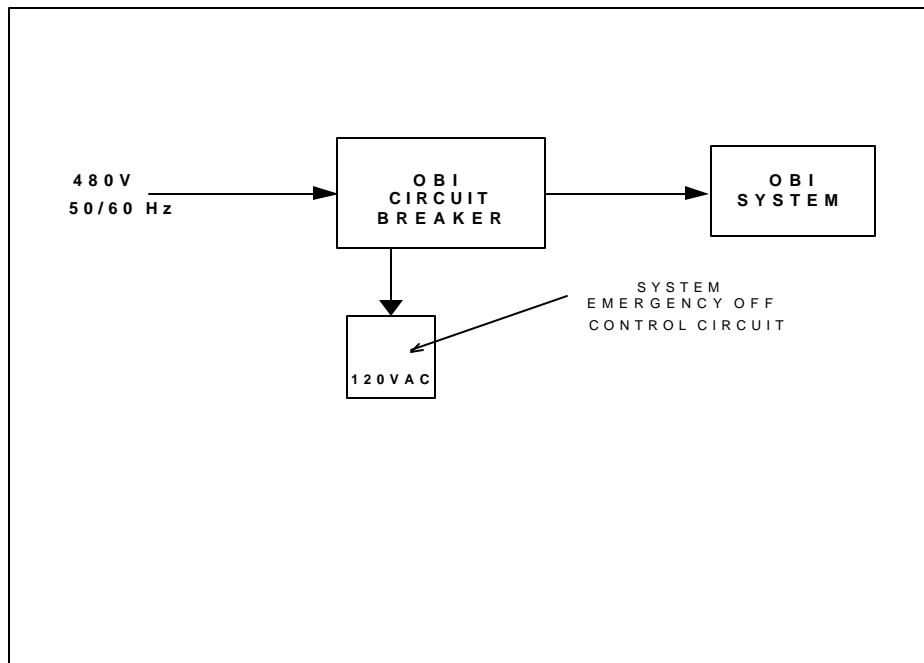

Physical Specifications

Height: 24 inches (609.6 mm)
Width: 14.6 inches (370.8 mm)
Depth: 6 inches (approx.) (152.4 mm)
Weight: ?? pounds (27.2 kg)

Main lug wire 3/0 max.

Mounting: Via keyhole slots: width is 9.5 inches on centers.
Height is 22 inches on centers (see diagram).

Catalog #: OBI60A480V

60 Ampere, 480V, 50/60 Hz, Surface or Semi-Flush mounting.

**Available from GE Supply National Service Center,
1-800-200-9760 Shawna Shiver.**

g OBI Circuit Breaker Panel

Conduits may enter or exit from top, bottom, sides or rear. Exact location must be field verified.

4" of enclosure may be recessed in wall for semi flush installations.

Products

All products have provisions for 120V, 50/60 Hz control.

Catalog #: OBI60A480V

60 Ampere, 480V, 50/60 Hz, Surface or Semi-Flush mounting.

Available from GE Supply National Service Center, 1-800-200-9760 Shawna Shiver.

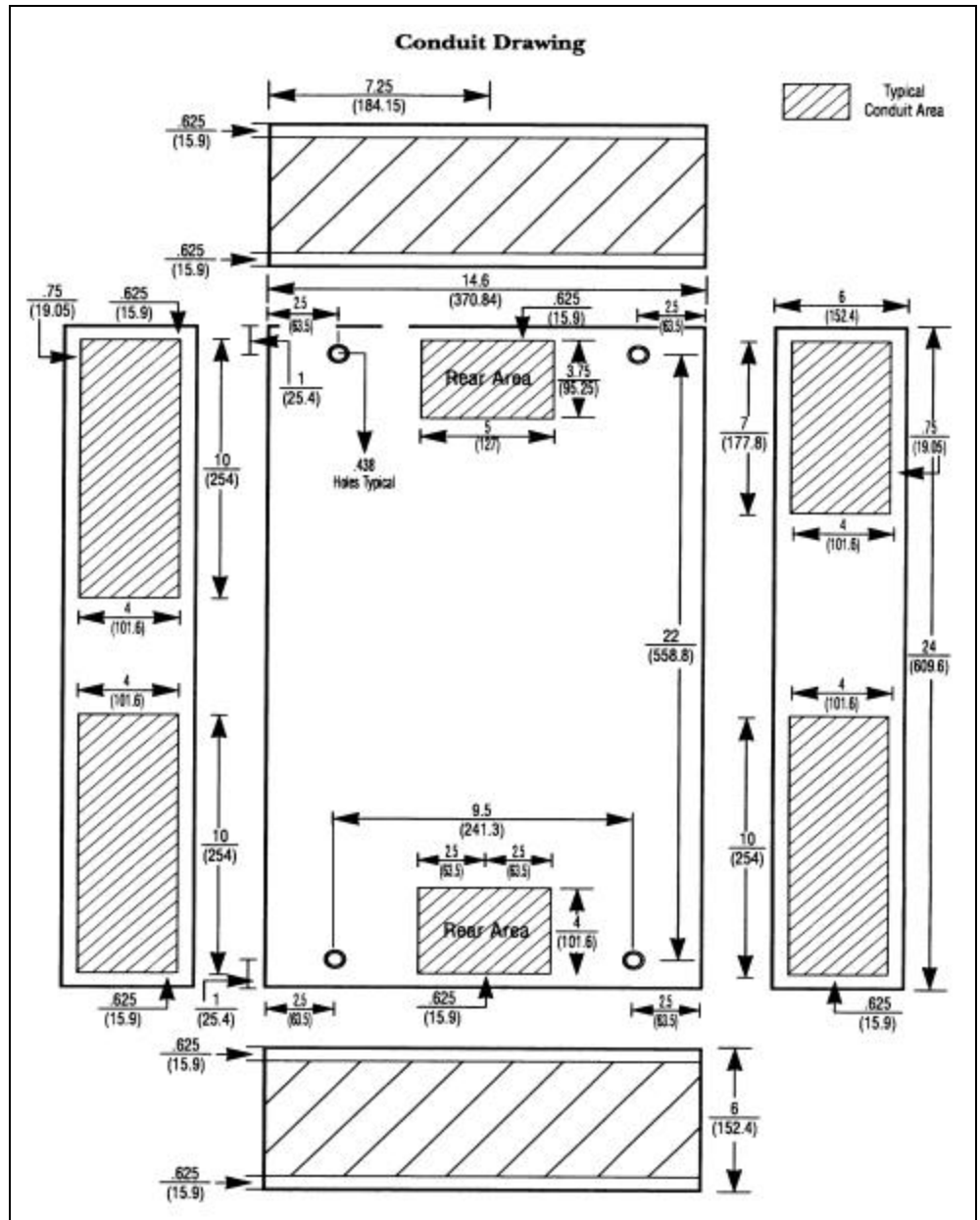

Raceway Solutions for Healthcare Applications

Walker Wallduct is a high capacity raceway for use in walls or ceilings. It can be mounted to the wall surface or flush with the wall to meet equipment layout and room designs. The lay-in feature for enclosure of wire and cable is ideal for use in healthcare rooms, under raised floors, or as a large capacity feeder for perimeter raceway. The cover plates are easily removed for wire and cable access. Wallduct can be used with Trenchduct to carry wire and cables from cabinets to egress points anywhere on the floor or wall. Aluminum Wallduct for applications requiring nonferrous metal raceways such as X-ray and MRI scan rooms is also available. Walker Wallduct is UL Listed to U.S. and Canadian safety standards.

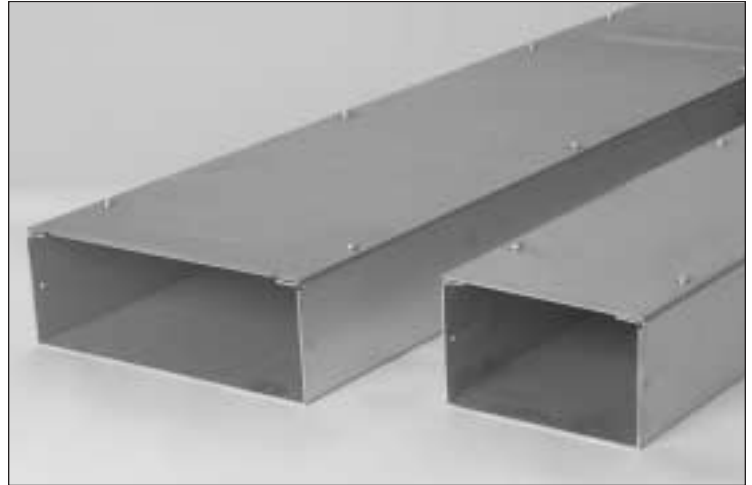

Wallduct is ideal for use in medical scan rooms.

Features & Benefits

- **Constructed of galvanealed steel or aluminum.** Provides extra corrosion resistance and is easily painted to match any room interior.
- **Interior couplings.** Offer improved aesthetics when surface mounted.
- **Complete line of fittings.** Reduces field modifications by minimizing installation time and costs.
- **AutoCAD® capabilities for detailing project drawings.** Provides high quality detailing information with the option of electronic communication for a quicker, more accurate exchange of information.
- **Three standard widths.** Provide cable and wire requirements for most applications.

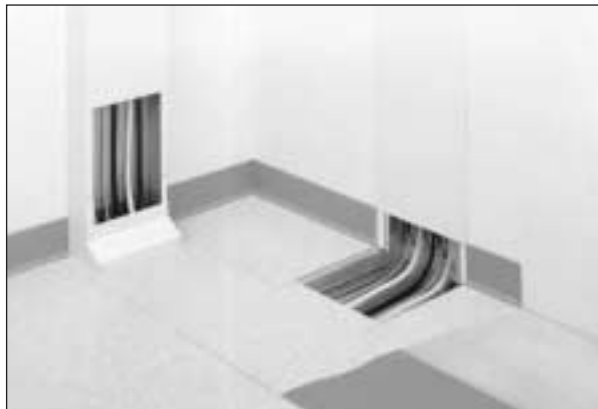

Walker Wallduct Steel or Aluminum Raceway with lay-in features for enclosure of wire and cable.

Wallduct System Layouts

Wallduct is commonly used in the healthcare market to feed wires and cables from electric and communication cabinets to X-ray and MRI equipment. See typical application shown. Because some healthcare equipment requires nonmetallic material in the surrounding area, aluminum Wallduct is used in scan rooms. The equipment and control rooms generally use steel Wallduct.

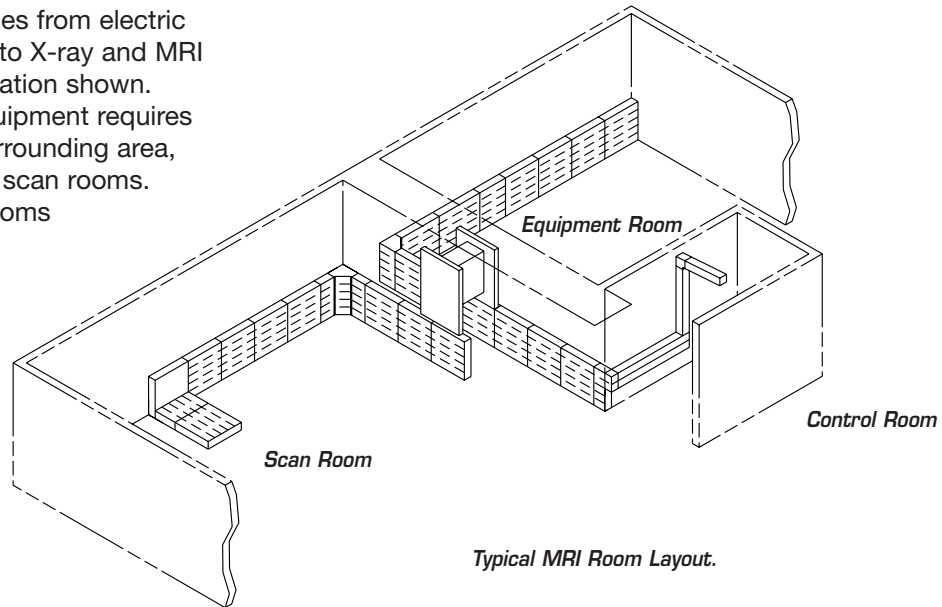

Typical MRI Room Layout.

Wallduct and Trenchduct Legend

Item	Catalog No.	Description
1	WD10W350-60	5'-0" [1524mm] Straight Length.
1a	CP10-F30	30" [762mm] L Flush Cover Plate.
2	WD10W350-IL	Internal Wallduct Elbow.
2a	CP10-ILF	Internal Wallduct Elbow Cover Flush.
3	WD10W350-HL	Horizontal Wallduct Elbow.
3a	CP10-HLF	Horizontal Wallduct Elbow Cover Flush.
4	WD10W350-T	Wallduct T-Unit.
4a	CP10-TF	Wallduct T-Unit Cover Flush.
5	WD10W350-X	Wallduct X-Unit.
5a	CP10-XF	Wallduct X-Unit Cover Flush.
6	WD10W350-ECF	Wallduct End Closure.
7	VA12W250H-5	VA Style Trenchduct 12" Wide x 2 1/2" Deep [304mm x 63mm].
8	VA12W250H-EC	VA Style Trenchduct End Closure.
9	VA12W250H-LL	VA Style Trenchduct Horizontal Elbow (Left Hand).
10	VA12W-VR10	VA Style Trenchduct Vertical Riser.
11	WD10W350-CC/DO	Wallduct Cabinet Connector.
12	WD350-CP	Corner Partition.
13	WD350-P60	Straight Partition.
14	WD10W350-TUN	T-Unit Straight Tunnel.
15	WD10-ACPF	Access Cover Plate With Grommet.
16	WD10W350-EL	Wallduct External Elbow.
16a	CP10W350-ELF	Wallduct External Elbow Cover Flush.
17	WD10W350-FST	Wallduct Flush to Surface Transition.
18	WD10W350-LTUN	T-Unit Left Hand Tunnel.
19	WD10W350-XTUN	X-Unit Tunnel.
20	T250HZP-5	Trenchduct Partition.
21	VA12W-VL10	Trenchduct Vertical Riser
22	WD10W350-FCCF	Flanged Cabinet Connector Flush.
23	WD10W350-SWTS	Sweep Surface Tee.
24	WD-10CDO	Ceiling Drop Out.
25	WD350-R04	Wallduct Reducer.
26	WD18W350-SWCCS	Sweep Cabinet Connector Surface.
27	WD10W350-SES	Sweep Elbow Surface.

Wallduct can be installed in the wall exposing only the cover plate, or it can be wall mounted exposing the entire surface. Wallduct may also be installed overhead to connect cables/wires between rooms. Trenchduct can be used in combination with Wallduct as a feeder or for access points in the floor to feed equipment. Diagram below is for illustration only. It does not portray typical installation of products

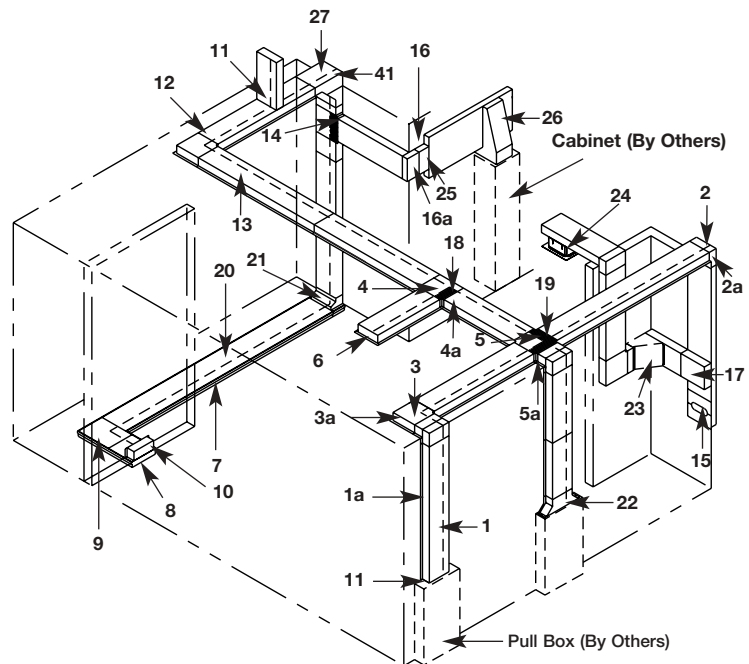

THIS IS AN EDITED VERSION OF THE WIREMOLD ED737R3 DOCUMENT. FOR THE LATEST SPECIFICATIONS AND WIREMOLD INFORMATION, IT CAN BE OBTAINED FROM THEIR WEB PAGE:

WWW.WIREMOLD.COM

To Wiremold.com ▶▶▶
Editable Guide Form Specs
CAD Drawings



Walker Systems, Inc.
U.S. and International:
1000 Innovation Drive • Williamstown, WV 26187
1-800-240-2601 • FAX 800-831-0321 • Outside U.S.: 800-233-6251
Canada:
850 Gartshore Street • Fergus, Ontario N1M 2W8
1-800-741-7957 • FAX 519-843-5980

